

High throughput WMN for the communication in disaster scenario

Auberlin Paguem Tchinda¹, Gregor Frick¹, Ulrich Trick¹, Armin Lehmann¹, Bogdan Ghita²

¹Research Group for Telecommunication networks, Frankfurt University of Applied Sciences, Frankfurt/Main, Germany
{ paguem, frick, trick, lehmann }@e-technik.org

²Centre for Security, Communications and Network Research, University of Plymouth, Plymouth, United Kingdom
{ bogdan.ghita }@plymouth.ac.uk

Abstract— The Wireless mesh network (WMN) is a popular network architecture used to support disaster recovery operations. However, few research works have addressed the capacity problem of such a network. This is due to the assumption that the communication network in disaster scenario is built to support services with a low rate requirement like delay tolerant messages. At the same time, the demand for higher data rates has increased in recent years due to the digitalisation of rescue operations and the use of new services (e.g. VoIP, drones and robots). Therefore, the capacity of the WMN is becoming a central issue in the design of future WMNs. This paper proposes a Layer 1 cluster-based network to solve the throughput bottleneck in the WMN. The proposed architecture is evaluated by several real world measurements. The obtained results are compared with the theory. The proposed solution shows a throughput improvement compared to a single-radio WMN and a multi-radio WMN using the CoMTaC channel allocation strategy.

Keywords—wireless mesh network, ieee802.11, disaster network, performance evaluation, channel assignment

I. INTRODUCTION

Today, the telecommunication network is a central element in the organisation and realisation of industrial and social processes. Its importance is particularly significant when it comes to rescuing people after a disaster. However, the research results published in [1] and [2] state that common communication infrastructures such as the mobile phone network are affected in disasters. This results in the need for a functioning additional communication network infrastructure immediately after the event.

A Wireless Mesh Network (WMN) is a decentralised network architecture that can be used to build the communication infrastructure in such scenarios ([3], [4], [5]). Figure 1 shows a typical WMN deployment. The network is

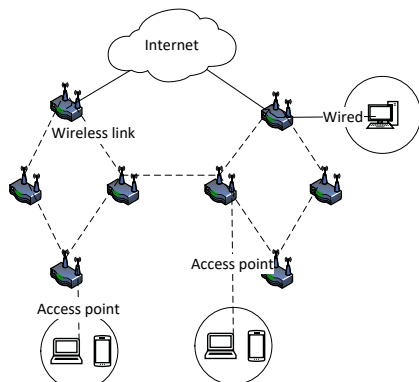

Fig. 1. WMN architecture

built by six WLAN routers. Two of them are connected to the internet via a wired connection. These routers are called mesh gateways because they provide access to external networks. Other routers within the network use their wireless interface to extend the connection provided by the mesh gateways or to forward traffic between them. These WLAN routers are referred to as mesh routers. In many cases, they also provide access point functionality for clients in the neighborhood via a second wireless interface.

Although several publications ([3], [4], [5]) have suggested the use of WMNs to solve the communication problem after disaster events, no research has yet been conducted to determine the capacity of such a network. Questions regarding link capacity, distance between mesh routers, the wireless standard used, the frequency bandwidth and channel width used, network coverage and hardware requirements remain unexamined. Answering these questions is the aim and a major contribution of this paper. The second contribution of this paper is the evaluation of the existing channel assignment strategies in the WMN. This evaluation is done with special emphasis on the results of real world throughput and interference measurements. The third and most important contribution of this paper is the proposal of a scalable WMN architecture that allows an optimal use of multi-radio and the channels available in IEEE802.11.

This paper is structured as follows: chapter 2 clarifies the challenges in providing a communication network infrastructure for the disaster scenario and identifies interference as the most important problem to be solved. Chapter 3 presents related work on existing channel allocation strategies in WMN. Chapter 4 presents the results of transmission range, interference range, network coverage and throughput measurement in single- and multi-radio WMN. These results are used to evaluate the channel allocation strategies presented in chapter 3. Since none of the existing strategies can handle the interference and channel limiting of the IEEE802.11 standard, a new solution is proposed that exceeds the existing strategies in chapter 5. Chapter 6 concludes this paper.

II. CHALLENGES AND OPEN ISSUES

This chapter introduces the challenges of providing a communication network in disaster scenario. In a second step, the challenges are used to define the requirements for the network infrastructure. Finally, the first characteristics of a desired architecture are presented and open questions are clarified.

In order to identify the challenges in the deployment of a communication network in disaster scenario, the normal state

has to be defined. This state is characterised by a geographical location, a population living and working in this area, a communication network infrastructure that serves the exchange of information between residents (e.g. the mobile communication network or the landline network) and the presence of other infrastructures such as roads, buildings and power supply (see Figure 2). The functioning of this normal state is usually affected by a disaster event. This event leads to a differentiation in the population. A typical differentiation consists of people who have lost their lives, people in need (e.g. injured), helpers and other affected persons. Another consequence of the disaster event is the partial or complete destruction of infrastructures within the affected region. This includes the infrastructure of the communication network (see Figure 2).

The organisation of the rescue response leads to some infrastructure demands across the different population groups. The focus of this paper is set on the communication demand, which can be described as follow:

- People in need require a way to make an emergency call.
- Helpers require depending on their organisation a way to communicate with the different leaders in the

command chain, a way to communicate or exchange information with other organisations, a way to do monitoring of the team deployment inside the disaster area, a way to use and communicate with helper devices (e.g. drones, medical robots).

- Other affected people are usually interested in receiving information on how to behave and answers to the questions "Where can I find something (e.g. water, food, accommodation)".

Based on this demand, the following requirements for the network infrastructure can be defined:

- Rapid deployment: Every minute is important for people in need. Therefore the disaster network has to be deployed as quickly as possible.
- Complete area coverage: The deployed network has to provide a complete coverage of the affected region to assure the access to all user groups.
- Easy deployment: No communication network knowledge must be necessary by the helpers to establish the network in the disaster area. Therefore the complexity of this process has to be as low as possible.

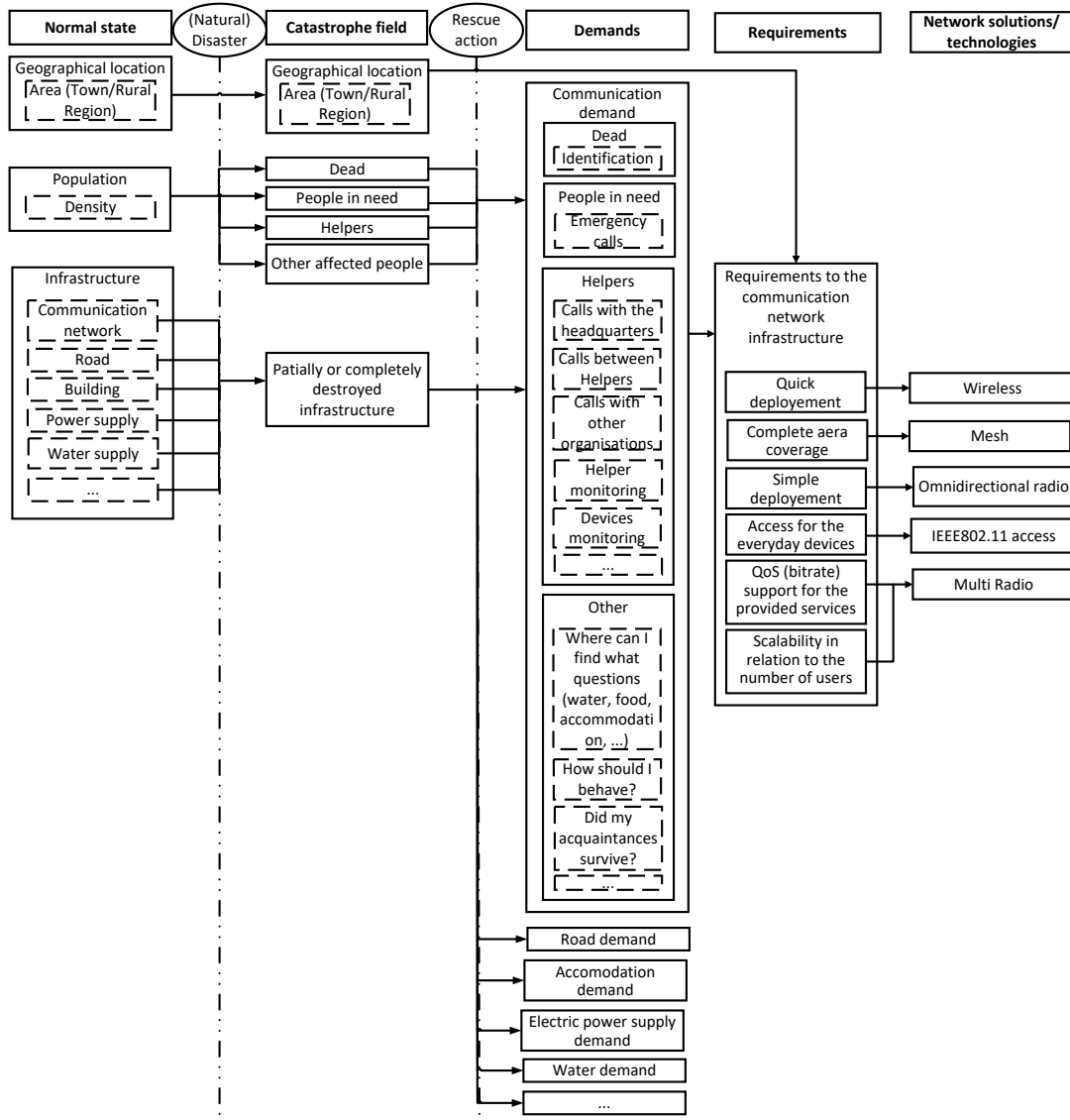

Fig. 2. Network infrastructure requirements and WMN characteristics

- Access for everyday devices: To make sure that the major part of users (people in need, helpers and other affected people) can access to the network, the access has to be guaranteed by a common technology.
- QoS support for the provided services: Multiple network services have to be provided for the different user groups. For example a SIP media server for VoIP calls between helpers in the field and the headquarters or a web server to inform people living in the affected region or a database for the information exchange between the involved organisations. Each of these services has a specific QoS requirement, which needs to be supported by the network.
- Support for variable number of helpers: The density of the population can change depending on where the disaster happen. A prioritisation of the services provided to the different user group also has to be done (e.g. prioritisation of calls).

Based on the above identified requirements, a first specification of the communication infrastructure in disaster scenario can be defined (see Figure 2).

The first feature that can be derived is the use of wireless technology. This feature is a consequence of the demand for rapid network deployment. A wired network typically needs more time and planning in order to be deployed. This type of network is therefore unappropriated for the disaster scenario. Due to the limited transmission range of wireless technologies, which cannot guarantee the complete coverage of the disaster area, a mesh topology is required. This topology represents the second feature of the network. The third feature that can be derived from the defined requirements is the use of WLAN (IEEE802.11) for the network access. This technology is currently the most widespread and near to all devices (e.g. smartphone, laptop) have a WLAN interface. Furthermore the bitrate reached by WLAN allows the support of the most used applications. Another feature of the network is the use of omnidirectional antennas to maintain the deployment process easy as possible. The support of several services and various number of user can be addressed through the network link and path throughput. The IEEE802.11ac standard defines a theoretical link throughput up to 3466.8 Mbit/s using 4x4 MIMO and a channel bandwidth of 160MHz [18]. On the other hand the path throughput inside a single-radio mesh network depends on the number of mesh routers interfering together $1/\sqrt{n \log n}$ due to the sharing nature of the wireless medium [7]. One solution to avoid the network throughput decrease is the use of multiple wireless-radios running on different channels. This leads to the problem of channel assignment. This problem is going to be addressed in the next chapter.

III. RELATED WORK ON CHANNEL ASSIGNMENT

This chapter introduces the different channel assignment (CA) strategies in multi-radio WMN and compares them in order to determine which one is the most appropriated for the network infrastructure in disaster scenario. The CA in WMN consists of the following optimisations tasks: interference minimisation, throughput maximisation and network connectivity preservation.

There are several ways to classify CA strategies. In [9] the authors differentiate between static or fixed, dynamic and hybrid CA strategies. By static or fixed CA strategies, a

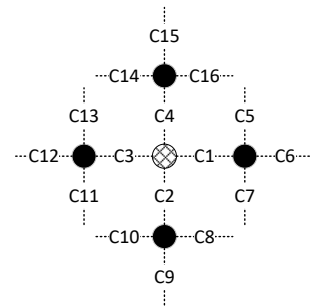

Fig. 3. Example of link based channel assignment

constant channel is set to each interface. By hybrid CA strategies, the channel allocation change (e.g. to adapt to the measured interferences or the changes in the network traffic). The hybrid CA is a combination of the two other strategies. This means that for some interfaces a static channel is assigned, and for others the channel allocation is optimised during the time.

In [10] the CA strategies are classified in centralised and distributed mechanisms. Centralised strategies require the presence of a central element that has knowledge of the entire network topology. This element performs the channel allocation and distributes this information over the whole network. In decentralized CA strategies, each node allocates channels to its interfaces using the local available information.

This paper distinguishes between link based and cluster based CA strategies:

In link based CA strategies (e.g. [10] and [11]), each interface is set to a specific channel for the communication with each neighbour. This strategy has the benefit to maximise the network throughput but also has three major drawbacks. First, it requires a high number of radio interfaces (one interface for each neighbour router) in order to preserve the network topology (topology preservation). For example, inside a WMN where each router communicates with four neighbour routers, four interfaces are required to maintain the network topology. If each router does not have four interfaces, additional calculations and optimisations are required to maintain network connectivity and avoid network segmentation. These additional optimisations represent the second drawback of link based CA strategies. The last drawback is the large number of non-overlapping channels required to build the network. Looking at the network topology in Figure 3, where each router has a communication link with its four neighbors, at least 16 non-overlapping channels are required to build the network (see Figure 3). This value is determined by the assumption that interference is limited to the neighboring routers. According to [12], the interference range of a wireless router can be considered to be two times its transmission range. That means a used channel can only be reused after two hops. This increases the number of required non-overlapping channels.

In the cluster based CA strategies, the number of wireless routers communicating on a same wireless link or channel is not limited to two. Many routers inside a cluster are using the same channel. The advantage of this strategy is that only few interfaces are required, the network topology is preserved and the number of required non-overlapping channels is lower. Few research works have addressed the channel assignment problem in multi-radio WMN using the cluster based solution so far. In [13] the authors propose the Cluster-based Multipath Topology control and Channel assignment scheme

(CoMTaC). The CA in CoMTaC is performed in three steps. In the first step, the network is parsed in cluster using a spanner algorithm. This process assumes that the traffic in the network is directed to the gateways and can lead to the loss of existing links. In the second step, interfaces are assigned to the neighbours. The third step is the channel assignment step. In this step, the default interface of each cluster member is assigned to a common default channel. After that the second interface of each border router is set a common channel to the interface in the neighbour cluster. This channel is different to the channels used inside the cluster. Finally, the CA for the rest interfaces of the cluster members is performed. This CA strategy can lead to the partition of the topology because a border router can provide a connection to more neighbour clusters than the number of interfaces that it has. This problem is addressed by the authors in [14], who propose the cluster-based channel assignment (CBCA). In order to avoid the partition of the network, CBCA starts the CA process with the border routers. Additionally the connection between border routers in CBCA is not limited to P2P. The same channel can be used to communicate with more than one neighbour cluster.

The main objective of the cluster based channel assignment strategy proposed by [15] is to avoid information over the channel usage to be distributed over the whole network. To achieve this goal, a head of cluster heads is introduced. It defines which channels can be used inside which cluster and distribute this information to the cluster heads. The cluster heads can then process the channel allocation to the cluster members.

It is important to mention that none of the above described CA strategies have addressed the problems of cluster sizing, network coverage or wireless standard usage. They also assume that interferences are reduced by the use of multi-channels, but do not provide evidence that the strategy that they propose is the best.

IV. MEASUREMENT AND EVALUATION OF EXISTING CHANNEL ASSIGNMENT STRATEGIES

This chapter presents the results of throughput measurements performed in order to evaluate the channel allocation strategies presented in chapter 3. The aim of the first series of measurements is to determine the transmission range of WLAN. The interference range of WLAN is determined via the second series of measurements and an interference model is proposed. The third measurement series determines and compares the results of the throughput in multi-radio multi-channel WMN with the results of the throughput in single-radio single-channel WMN. The chapter concludes with a comparison of the CA strategies presented in chapter 3. The measurement testbed and the used hardware are described in the first section. The measurements were performed only at

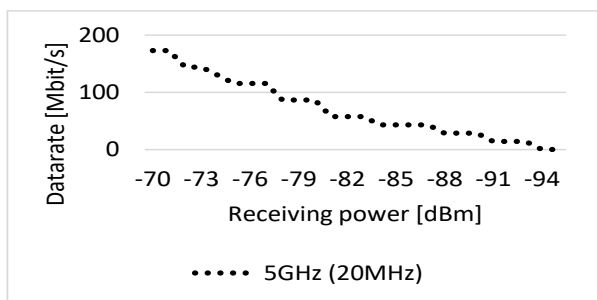

Fig. 4. – Sensibility of the WLE600VX WLAN module, IEEE802.11n, 20MHz [16]

the 5GHz frequency band. The 2.4GHz frequency band provides 4 non-overlapping channels in the EU (European Union) and 3 in the USA and is therefore not suitable for the use in multi-channel WMN.

A. Description of the measurement testbed

The measurements were performed in a garden outside the town to avoid interferences with other WLAN devices in the neighbourhood. For the measurement four fanless mini PCs were used. Each mini PC was equipped with two WLE600VX wireless modules. This wireless module uses a Qualcomm-Atheros QCA9882 chipset [16]. The chipset implements a 2X2 MIMO and the IEEE802.11a/ac/b/g/n wireless standards. Figure 4 shows the sensitivity of the chipset when using the IEEE802.11n standard in the 5GHz frequency band with a channel bandwidth of 20MHz. According to the data sheet, a theoretical data rate of 173.3Mbit/s is expected for a receiving power of more than -71dBm at 5GHz. For the connection between the wireless module and the antennas outside the box, a cable with an attenuation of 0,7dB at 5GHz was used [17]. Two antennas were attached to each wireless module with a gain of 4,5dBi at 5GHz. During the measurement the mini PCs were set to a height of 3m above the floor with the help of a tripod. The measurement duration was 90 second.

B. Transmission range

In this section the transmission range of IEEE802.11n is determined and the results are compared with the theoretical expectations.

Figure 5 shows the setup for determining the transmission range. The power at the receiving station P_B can be calculated using the following equation:

$$P_B = P_A - A_A + G_A - PL + G_B - A_B - \text{Fade Margin} \quad (1)$$

where P_A is the transmitting power, A_A is the attenuation between the transmitter wireless module and the transmitter antenna, G_A is the gain of the transmitter antenna, PL is the path loss during the transport between transmitting and receiving station, G_B is the gain of the receiver antenna, A_B is the attenuation due to the transport between receiver antenna and receiver wireless module, Fade Margin is the allowed error during transmission.

This paper uses the free space path loss to estimate the attenuation due to the transport through the wireless medium. This estimation can be done due to the absence of obstacles and reflexions in garden. The free space path loss is given by the equation

$$PL = 20 \log(d) + 20 \log(f) - 147.55 \quad (2)$$

d is the distance between transmitting and receiving mesh router in m (see Figure 5) and f is the frequency in Hz.

The standard procedure for determining the transmission range is to measure the data rate change depending on the distance between transmitter and receiver, at a constant transmitting power. This procedure requires a movable power supply to operate the mini PCs and adequate length of the measurement field. The length of the garden was 100 m and thus below the expected range. Therefore, an alternative

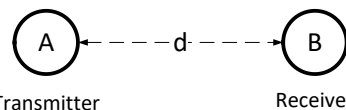

Fig. 5. Setup for determining the transmission range

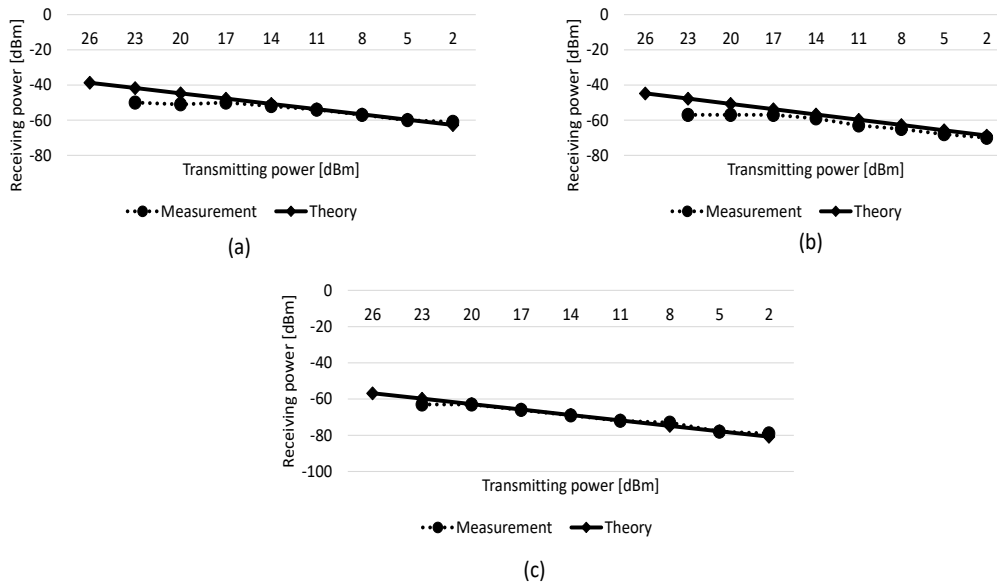

Fig. 6. Comparison between theory and measured receiving power at channel 36 – 5.18GHz (a) 10m, (b) 20m and (c) 80m

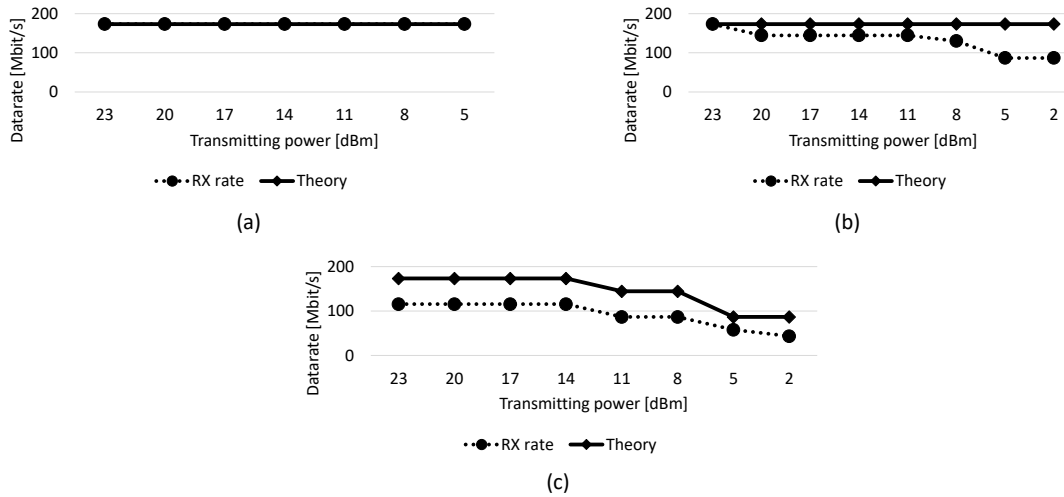

Fig. 7. Comparison between the measured RX rate and the expected value according to the measured receiving power at channel 36 – 5.18GHz (a) 10m, (b) 20m and (c) 80m

measuring method was used. The sending power of the transmitting router was varied to simulate a distance change (a change in the path loss) between transmitter and receiver (see equation 1 and 2).

Figure 6 resumes the results of the power measurement at the receiver. The receiving power was determined at the receiver using the Linux tool `iw` and compared with the theoretical expectation. The theoretical expected values are calculated using the equations 1 and 2. The *Fade Margin* was set to 0 and the hardware characteristics (antenna gain and cable attenuation) introduced in section A were used. The measurements were performed for the distances 10, 20 and 80m. The measurements were done by channel 36 (5180MHz) at the 5GHz frequency band. The transmission power was varied between 23dBm and 2dBm.

The measured receiving power is almost identical to the theoretical expectation. A small deviation can be observed with a transmission power higher than 17dBm. A closer look in the datasheet of the wireless module shows a maximal transmission power of 16dBm if the modulation and coding

scheme (MCS) 8 is used at 5 GHz. This maximal value increases to 22dBm by the lowest MCS 0 and explains why theory and expected values are near to identical at 80m.

In a second step, receive bit rates (RX rates) were measured for the receiver chip. These values were compared with the expected values from theory. The theoretical receive bit rates can be determined from the measured receive power. For this purpose, the measured receive powers (see Figure 6) are compared with the sensitivity of the wireless module in Figure 4 (e.g. a receive power above -71dBm leads to a theoretical receive bit rate of 173.3Mbit/s). The results of the comparison are shown in Figure 7. A discrepancy between the two values can be observed. This means that the used MCS is lower than the value specified by the manufacturer of the wireless module. This discrepancy increases with distance, as shown in Figure 7, making it impossible to predict the RX value based on the calculated receive power and sensitivity of the wireless module.

Steps 1 and 2 have shown that it is impossible to determine the transmission range from purely theoretical considerations.

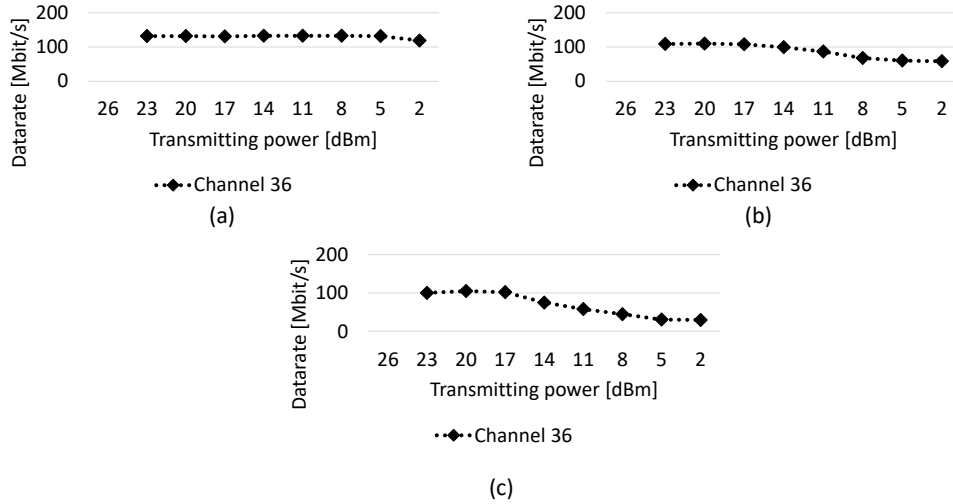

Fig. 8. Measured TCP bitrate depending on the transmission power at channel 36 – 5.18GHz (a) 10m, (b) 20m and (c) 80m

It is therefore necessary to estimate the transmission range based on the measured bitrate values. For this purpose a TCP measurement was performed between transmitting and receiving router. The results are presented in Figure 8. It is important to note that the measured TCP bitrates are below the measured RX rates in Figure 7. This is due to the overhead caused by IEEE802.11 management frames (beacon frames) and the headers of the underlying protocols to TCP. According to the results presented in Figure 8, if the transmitting power used by the sender is 17dBm, a TCP bitrate of 130Mbit/s at 10m, 108Mbit/s at 20m and 102Mbit/s at 80m can be expected.

Based on the measured bitrates at 10m, a prediction about the expected bitrates at 20m can be done. According to the equations (1) and (2) these values are obtained through a translation of 6dBm in the measured throughput. The same process can be applied to the measured values at 80m. As result, a TCP bitrate of 57,7 Mbit/s can be expected by a distance of 160m using a transmission power of 17dBm.

C. Interference range

Interferences occur when two or more mesh routers in the interference range of each other want to transmit on the same channel at the same time. In the literature two models are typically used to describe the interference range between mesh routers. The first one is the protocol model. It considers that two mesh points are interfering when they are in the carrier sense range of each other [6]. According to this model the interferences caused by a mesh point B in a few meter distance from a mesh point A and the interferences caused by a mesh point C far away is supposed to be the same as long as node C is inside the carrier sense range of node A. Because the carrier sense range of a node is at least as high as its maximal transmission range, this model leads to a high interference area and therefore to an important throughput decrease inside a WMN. The second model is the physical model, which considers that the interferences caused by a disturbing station depend on the difference between the signal strength from the disturbing router and the transmitting router at the receiver.

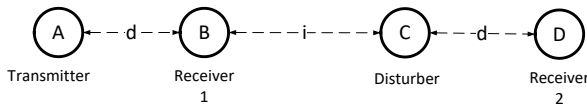

Fig. 9. Setup for determining the interference range

Again if the above described scenario is considered, the interferences caused by the node B will be higher than the interferences caused by the node C at node A.

This section aims to determine which model most accurately describes the interferences within the WMN. To achieve this goal, the following measurements were performed. Figure 9 describes the measurement testbed. The distance between transmitter (A) and receiver 1 (B) respectively between disturber (C) and receiver 2 (D) was 20m. The transmission power was set to a fixed value of 17 dBm at routers A and B. The transmission power was changed in 3dBm step on router C and D. This variation of the transmitting power was done to simulate an increase in the interference distance i between B and C. The TCP data stream was measured between A and B. At the same time another TCP transmission was started between C and D.

Figure 10 resumes the measurement results. It presents the measured TCP data rate between A and B depending on the receiving power from C at B. For a receiving power under -77dBm the measured bitrate is half of the expected bitrate without interferences. That means both routers A and C equally share the wireless medium as expected by the protocol model. For a receiving power between -78 and -87dBm, the measured throughput varied between 50 and the maximal value of 110 Mbit/s. In this segment of the graph the physical model is used. Below this value, the TCP stream between C and D has no influence on the stream between A and B.

D. Multi hop communication

In this section the expected throughput in a multi-radio WMN is measured and the results are compared with the throughput in a single-radio WMN. The measuring set-up consists of four stations at a distance of 5 m from each other

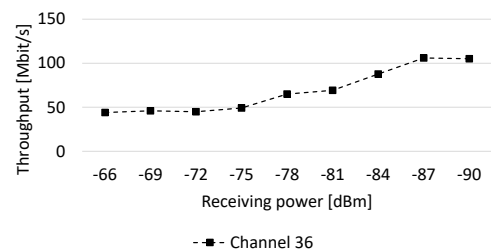

Fig. 10. Throughput depending of the receiving power of the disturber

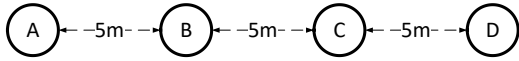

Fig. 11. Setup for determining the hop dependence of the path throughput

(see Figure 11). The Transmission power were set to 8dBm. In order to force the TCP stream to use the multi-hops path, the direct links between the routers A-C, A-D and B-D were disabled in both directions using the iw tool.

Figure 12 resumes the measurement results. According to these results the throughput inside a single radio WMN decreases to 50%, when the traffic goes through two hops. After three hops the measured throughput is near to 30% of the link throughput. In contrast, the TCP throughput remains constant when the traffic goes over several hops in multi-radio multi-channel WMN.

E. Evaluation of existing channel assignment strategies

In this section the channel assignment strategies presented in section 3 are evaluated. The evaluation is performed based on the following criteria: topology preserve, compliance with interference model, scalability of the channel assignment and network throughput. Table 1 resumes the evaluation results.

Link based (Lb) CA strategies like proposed by the authors in [10] and [11], preserve the network topology only if the number of wireless interfaces at each router is equal or higher than the number of neighbour routers. In this scenario, the number of required non-overlapping channels is higher than the number of channels available in IEEE802.11. This scenario is referenced in Table 1 as Lb(high). If the number of available interfaces is reduced to comply with the number of channels existing in the IEEE802.11 standards, the topology cannot longer be preserved. This leads to a high complexity of the channel assignment. This second scenario is referenced in Table 1 as Lb(low).

In CoMTaC [13] the proposed channel assignment strategy preserves the intra cluster topology by using a default channel. For the inter cluster communication, a peer link with the neighbour cluster is assumed. Because a border router can have more than one neighbour cluster, a partition of the network can occur. CoMTaC not really deals with interferences or uses any interference model. The cluster size is not specified. The authors recommend the formation of 2-hops clusters, as they assume the interference range to be two times the transmission range. However the throughput measurements in multi-hop scenario (see section D) have demonstrated that the throughput is reduced to 50% when the traffic goes over two hops.

CBCA [14] is a modification of CoMTaC, which aims to solve the problem of network partition. Both strategies therefore have the same characteristics concerning interference compliance, scalability and complexity.

In CCA [15], the network is parsed in clusters using a clustering algorithm. In each cluster, the node with the highest number of links is selected to become the cluster head. In a second step, a head of cluster heads is selected. This node distributes the available channels to the different clusters that it manages. The distribution of the available channels is performed depending on the size (number of members) of each cluster. The authors do not specify the used clustering algorithm or the size of the clusters. The proposed CA strategy maintains a distance of 2 clusters between clusters using the same channel set (list of channel assigned to a specific cluster

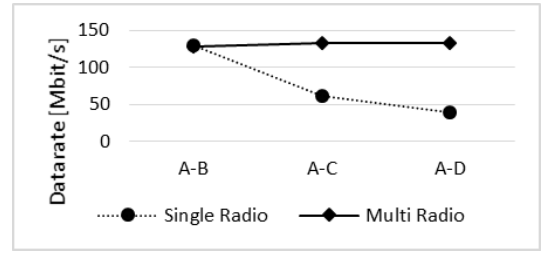

Fig. 12. TCP throughput depending of the number hop

by the head of cluster heads). According to the results of the throughput and interference measurements presented in sections B and C, the MCS2 is used for a transmission range that is half the interference range (RX rate 43.3Mbps, TCP bit rate proximal 26Mbps). This means that the throughput of a network using the CCA channel allocation strategy is low.

TABLE I. EVALUATION OF EXISTING CA STRATEGIES

| Evaluation criteria | CA strategy | | | | |
|----------------------------|-------------|---------|--------|------|-----|
| | Lb(high) | Lb(low) | CoMTaC | CBCA | CCA |
| Topology preserve | + | - | o | + | o |
| Interference compliance | - | + | - | - | - |
| Scalability and complexity | + | - | + | + | + |
| Throughput | + | + | - | - | - |

(+) fulfilled, (o) partially fulfilled and (-) no fulfilled

V. PROPOSED ARCHITECTURE

The measurements and the subsequent evaluation of existing CA strategies in chapter 4 have demonstrated the necessity to develop a new CA strategy, which can comply with the interferences in WMN. In this chapter a new architecture, which fulfils the high throughput requirement of WMN in disaster scenario is proposed. In the following the optimal size of the cluster is determined and a channel assignment strategy that respects the results obtained in chapter 4 is presented.

A. Clustering and cluster size

In this section, the optimal cluster size n_{opt} is determined. This size is defined by the two following optimisation objectives:

- The first optimisation objective consists of the minimisation of interferences or throughput maximisation. According to [7] the throughput inside a WMN, where routers can directly communicate with each other, is given by the equation

$$\frac{W}{\sqrt{n \log n}} \quad (3)$$

W is the expected link throughput for the Point-to-Point communication between two routers and n the number of mesh router, which build the WMN. This throughput decreases with the value of n . That means the number of router inside the cluster has to be low as possible to maximise the throughput.

- The second optimisation objective is to maintain the connectivity between mesh routers in the whole WMN. The maximal connectivity is achieved when no communication link is lost during the clustering

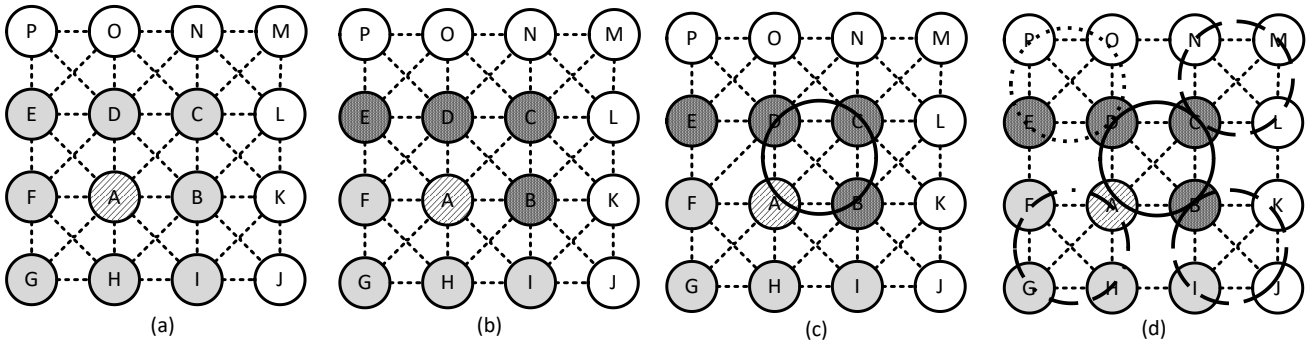

Fig. 13. WMN clustering (a) routers within the transmission range of A in gray, (b) routers assigned to the first interface of A, (c) cluster built by the routers A, B, C, and D (d) end state

process. For example if a communication network is considered where each router is equipped with two wireless interfaces, each interface has to be connected with the half number of neighbour routers. If each router is equipped with third interfaces, each interface must be connected to a third of the number of neighbouring routers.

In addition to these optimisation objectives, two optimisation constrains are also defined.

- First, the routers, which build the cluster must be in the transmission range of each other. This constrain is made to avoid the multi-hop transmission inside the same cluster. Inside a WMN, where routers communicate in a multi-hop manner using the same channel, the throughput decreases dramatically, as shown by the measurement in chapter 4.
- Second, a new cluster is built only if two or more cluster members provide a gateway functionality to adjoining clusters. This constrain is defined to avoid the partitioning of the WMN (network resilience [8]).

According to the above defined optimisation objectives and constrains, if the WMN topology in Figure 13a is considered, where each router can communicate with eight neighbour routers (routers within its transmission range) and is equipped with two wireless interfaces, the optimal cluster size n_{opt} can be determined using the following steps:

- First, neighbouring routers of router A are separated into two groups and assigned to one of its two interfaces depending on their location within the network. For example the first group is built by the routers B, C, D and E and is connected via the first interface. The second group consists of the routers F, G, H and I. These routers are connected via the second interface (see Figure 13b).
- Second, subgroups are created for each defined group in the first step. These subgroups consist of routers that are within communication range of each other and must contain Router A. The cluster is formed by the subgroup with the highest number of members. This step can lead to the loss of connections between Router A and the neighboring routers that are not part of the cluster. If the first group of the previous example is considered, the following subgroups can be built: (A, B, C, D) and (A, D, E). The cluster is built by the routers A, B, C and D. This leads to the loss of the link between A and E (see Figure 13c).

- Third, each group member that was not part of the selected subgroup to build the cluster will next be tested (e.g. router E). If a new cluster can be built, this is done according to step 1 and 2. If it is not the case (e.g. due to the second constrain), the router is attached to the current cluster.

Figure 13d shows the end state of the clustering process. The optimal cluster size for the examined topology is 4 ($n_{opt} = 4$).

B. Number of interfaces and channel assignment

In the previous section the optimal cluster size n_{opt} was determined. It was demonstrated that its value depends on two major factors: the number of interfaces and the number of neighbour routers. In this section the optimal number of interfaces ϵ_{opt} is determined in order to perform the channel assignment. This number is defined by the following constrains:

- First, the number of existing non-overlapping channels provided by the IEEE802.11 standard. This number is limited to three channels when the 2.4GHz frequency band is used and 23 in the EU (European Union) respectively 26 in the USA, when the 5GHz frequency band with a bandwidth of 20MHz is used [18] (only channel with a allowed transmission power higher than 20dBm).
- Second, the restriction is given by the channel re-usage. This depends on the interference range I_{rg} . A

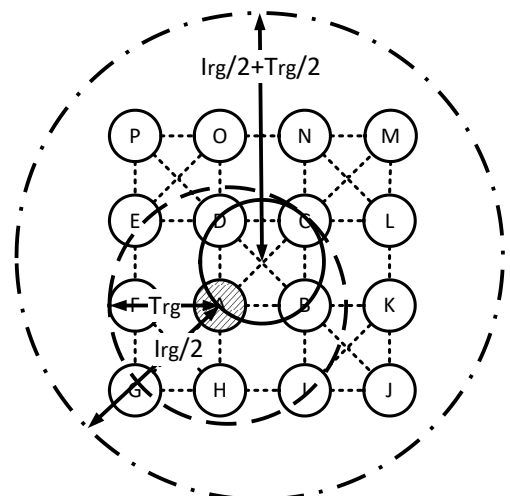

Fig. 14. Estimation of the required number of non-overlapping channels

channel should not be used by two clusters within the interference range of each other.

If a network topology is considered, where each router is equipped with ε wireless interfaces and has β neighbouring routers (number of routers within its transmission range). According to the measurement results presented in chapter 4, the transmission range T_{rg} can be written as a fraction of the interference range I_{rg} ($T_{rg} = \frac{I_{rg}}{\alpha}$). The value of the factor α depends on the wished data rate und was estimated to proximally four resp. eight, when a TCP bitrate of 80Mbit/s resp. 110Mbit/s is required between the different cluster members.

Assuming router A is member of a cluster (see Figure 14). All members of the same cluster must be within the transmission range T_{rg} of router A. The center of the cluster must be in a maximal range of $\frac{T_{rg}}{2}$.

If the channel C_0 is used for the communication inside the cluster, this channel should not be used by another cluster within the interference range. To achieve this goal, if the cluster is considered to be in center of the network, a range of $\frac{I_{rg}}{2} + \frac{T_{rg}}{2}$ must be covered by no-overlapping channels (see Figure 14).

The number of routers N inside this area can be calculated using the following equation

$$\begin{aligned}
 N &= \text{area} \times \text{density} \\
 &= \pi \left(\frac{I_{rg}}{2} + \frac{T_{rg}}{2} \right)^2 \times \text{density} \\
 &= \pi \left(\frac{I_{rg}}{2} + \frac{T_{rg}}{2} \right)^2 \times \frac{\beta}{\pi T_{rg}^2} \\
 &= \left(\frac{\alpha + 1}{2} \right)^2 \beta
 \end{aligned} \tag{4}$$

The total number of wireless interfaces inside this area is given by

$$\varepsilon N = \frac{(\alpha + 1)^2}{4} \varepsilon \beta \tag{5}$$

If the number of cluster member is equal to n_{opt} , the number of cluster γ and therefore the number of required non-overlapping channels can be determined with the equation

$$\gamma = \frac{\varepsilon N}{n_{opt}} = \frac{(\alpha + 1)^2}{4} \frac{\varepsilon \beta}{n_{opt}} \tag{6}$$

That means, if the network topology in figure 13 is considered, in which each router is equipped with two radio interfaces ($\varepsilon = 2$) and has eight neighbouring routers ($\beta = 8$), the maximal value of α and therefore the maximal throughput of the network can be calculated for the optimal cluster size $n_{opt} = 4$ (see demonstration in section A). This value is calculated for $P = 26$ (number of non-overlapping channels). The value of α is obtained by reformulating the equation 6

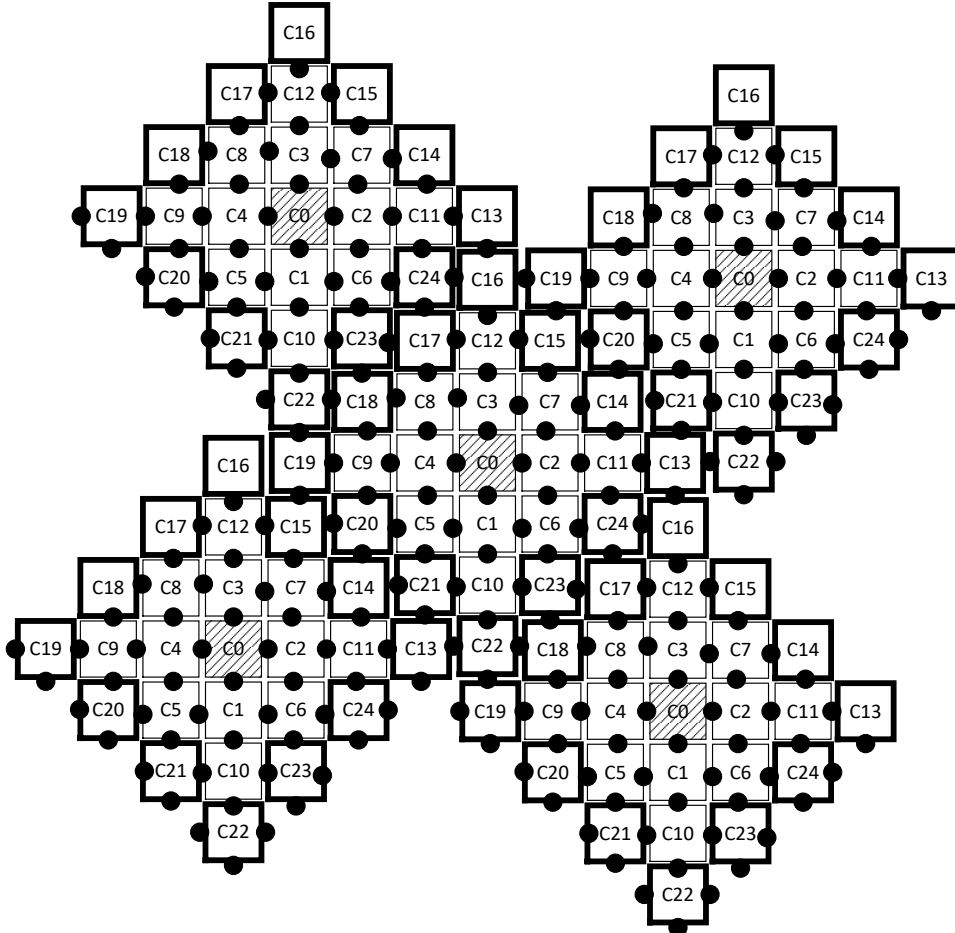

Fig. 15. Optimal channel assignment for a grid topology

$$\alpha = \sqrt{\frac{4\gamma n_{opt}}{\varepsilon\beta}} - 1 \quad (7)$$

and is equal to $\alpha = 4,1$.

That means, the maximal network throughput is obtained, when the transmission range is one quarter of the interference range. According to the measurements in chapter 4, this throughput is proximally equal to 80Mbit/s.

On the same way, it can be demonstrated that no throughput improvement (higher value of α) can be reached through additional interfaces. For example, if the same network topology is considered with the difference that each router is equipped with four instead of two interfaces, each interface is now connected to two neighbours and the optimal cluster size $n_{opt} = 3$. In this case $\alpha = 2,6$. That means $T_{rg} = I_{rg} / 2,6$. The expected TCP throughput at this distance is estimated to 26Mbit/s.

Figure 15 shows the optimal CA within a grid topology, where each router is equipped with two radio interfaces and can communicate with eight neighbours. The clustering and CA was performed according to the proposed strategy. Figure 15 demonstrates that at least 25 non-overlapping channels are required to make sure that the minimal distance between routers using the same channel but member of different cluster is four times the transmission range.

VI. CONCLUSION

In this paper, the limitation of existing CA strategies in disaster scenario has been demonstrated. The evaluation was carried out on the basis of these criteria: topology preserve, interference compliance, throughput, scalability and complexity. It has been shown that none of the existing strategies can meet these requirements. This was done on the basis of literature review and multiple real world measurements. For example, in chapter 4 the transmission range of the WLAN router was determined. A TCP data rate of 70Mbit/s was estimated for a transmission range of 160m, when using the IEEE802.11n standard, at the 5GHz band and a sending power of 17dBm. According to the interference measurements, the interference range by this configuration can be estimated to 640m. A new CA strategy has been proposed to address the requirements in the disaster scenario in chapter 5. The proposed strategy solves the topology preserve requirement in WMN by implementing a cluster-based scheme in which each router attempts to maintain a connection with all routers within its transmission range. The interference compliance requirement is also solved through an optimal usage of the available non-overlapping channels in the IEEE802.11 standard and by taking care of the relationship between transmission and interference range ($T_{rg} = \frac{I_{rg}}{\alpha}$, where α can be higher than two). The throughput requirement is met by avoiding multi-hop communication within the same cluster (1-hop channel switching). The proposed strategy also solves the requirements for scalability and complexity by using locally available information (list of routers within the transmission and interference range) and not generating additional packets or changes to the standard.

ACKNOWLEDGMENT

The research project VirtO4WMN providing the basis for this publication is partially funded by the Federal Ministry of

Education and Research (BMBF) of the Federal Republic of Germany under grant number 13FH018IX6. The authors of this publication are in charge of its content.

REFERENCES

- [1] G. O'Reilly, A. Jrad, R. Nagarajan, T. Brown and S. Conrad, "Critical Infrastructure Analysis of Telecom for Natural Disasters," Networks 2006. 12th International Telecommunications Network Strategy and Planning Symposium, New Delhi, 2006, pp. 1-6.
- [2] ITU-T, "Technical Report on Telecommunications and Disaster Mitigation," FG-DR&NRR, Version 1.0, 06/2013.
- [3] A. Lehmann, A. Pagueu Tchinda and U. Trick, "Optimization of Wireless Disaster Network through Network Virtualization," 11th International Network Conference, Frankfurt am Main, 2016, pp. 165-170.
- [4] A. Yarali, B. Ahsant and S. Rahman, "Wireless Mesh Networking: A Key Solution for Emergency & Rural Applications," 2nd International Conference on Advances in Mesh Networks, Athens, Glyfada, 2009, pp. 143-149.
- [5] M. Portmann and A.A. Pirzada, "Wireless Mesh Networks for Public Safety and Crisis Management Applications," in IEEE Internet Computing, vol. 12, no. 1, 2008, pp. 18-25.
- [6] J. Wildman and S. Weber, "On protocol and Physical Interference Models in Poisson Wireless Networks," in IEEE Transactions on Wireless Communications, vol. 17, no. 2, 2018, pp. 808-821.
- [7] P. Gupta and P. R. Kumar, "The capacity of wireless networks," in IEEE Transactions on Information Theory, vol. 46, no. 2, 2000, pp. 388-404.
- [8] G. Frick, A. Pagueu Tchinda, B. Shala, U. Trick, A. Lehmann, and B. Ghita, "Requirements for a Distributed NFV Orchestration in a WMN-based Disaster Network," International Conference on Information and Communication Technologies for Disaster Management (ICT-DM), Paris, 2019, pp. 1-6.
- [9] H. Skalli, S. Ghosh, S. K. Das, L. Lenzini and M. Conti, "Channel Assignment Strategies for Multiradio Wireless Mesh Networks: Issues and Solutions," in IEEE Communications Magazine, vol. 45, no. 11, 2007, pp. 86-95.
- [10] B.J. Ko, V. Jisra, J. Padhye and D. Rubenstein, "Distributed Channel Assignment in Multi-Radio 802.11 Mesh Networks," WCNC, 2007, pp. 3981-3986
- [11] P. Kyasanur and N.H. Vaidya, "Routing and Link-Layer Protocols for Multi-Channel Multi-Interface Ad Hoc Wireless Networks," ACM SIGMOBILE Mobile Computing and Communications Review, vol. 10, no. 1, 2006, pp. 31-43.
- [12] A. Raniwala and T. Chiueh, "Architecture and Algorithms for an IEEE802.11-Based Multi-Channel Wireless Mesh Network," Proceedings IEEE 24th Annual Joint Conference of the IEEE Computer and Communications Societies, Miami, 2005, vol. 3, pp. 2223-2234.
- [13] A. Naveed, S. S. Kanhere and S. K. Jha, "Topology Control and Channel Assignment in Multi-Radio Multi-Channel Wireless Mesh Networks," 2007 IEEE International Conference on Mobile Adhoc and Sensor Systems, Pisa, 2007, pp. 1-9.
- [14] K. Athota and A. Negi, "A topology preserving cluster-based channel assignment for wireless mesh networks," International Journal of Communication Systems, 2014, pp. 1862-1883.
- [15] Makram SA, Gunes M. Distributed channel assignment for multi-radio wireless mesh networks. IEEE Symposium on Computers and Communications (ISCC), 2008; pp. 272-277.
- [16] Complex model WLE600VX, "Dual Band 5GHz 2x2 MIMO 802.11ac Mini PCIe WiFi Module: Designed for Dual Band Wireless Access Points".
- [17] Delock WLAN cable, "Delock RP-SMA Buchse zum Einbau > MHF/U.FL kompatibler Stecker 200 mm 1.37".
- [18] IEEE Standard for Information technology - Telecommunications and information exchange between systems Local and metropolitan area networks - Specific requirements IEEE802.11 "Part 11: Wireless LAN Medium Access Control (MAC) and Physical Layer (PHY) Specifications," IEEE Computer Society, IEEE Std 802.11™-2016, 2016.